



US00D598433S

(12) **United States Design Patent**  
**Schneider et al.**

(10) **Patent No.:** **US D598,433 S**

(45) **Date of Patent:** **\*\* Aug. 18, 2009**

(54) **TAPERED LOOP ANTENNA ELEMENT**

(75) Inventors: **Richard E. Schneider**, Wildwood, MO (US); **John Edwin Ross, III**, Salt Lake City, UT (US)

(73) Assignee: **Antennas Direct, Inc.**, Eureka, MO (US)

(\*\*) Term: **14 Years**

(21) Appl. No.: **29/304,423**

(22) Filed: **Feb. 29, 2008**

**Related U.S. Application Data**

(63) Continuation of application No. 12/040,464, filed on Feb. 29, 2008.

(51) **LOC (9) Cl.** ..... **14-03**

(52) **U.S. Cl.** ..... **D14/230**

(58) **Field of Classification Search** ..... D14/138, D14/230-238, 299, 358; D12/42, 43; 343/700 MS, 343/700 R-705, 711-713, 741, 748, 767, 343/795, 819, 840, 846, 866, 871-908; 455/90.2, 455/90.3, 91, 128, 269, 344, 347, 562.1  
See application file for complete search history.

(56) **References Cited**

**U.S. PATENT DOCUMENTS**

D170,203	S	*	8/1953	Leonard	.....	D14/230
3,015,101	A	*	12/1961	Turner et al.	.....	343/848
3,123,826	A		3/1964	Durham		
3,434,145	A		3/1969	Wells		
4,184,163	A		1/1980	Woodward		
D327,690	S		7/1992	Ogawa et al.		
5,313,218	A		5/1994	Busking		
D414,495	S		9/1999	Heiligenstein et al.		
6,593,886	B2	*	7/2003	Schantz	.....	343/700 MS
6,680,708	B2		1/2004	Yamaki		
6,885,352	B2		4/2005	Lee et al.		
7,091,925	B1		8/2006	Wang		
7,209,089	B2	*	4/2007	Schantz	.....	343/787

7,239,290 B2 7/2007 Poilasne et al.  
2002/0158798 A1 10/2002 Chiang et al.

(Continued)

**FOREIGN PATENT DOCUMENTS**

JP	D1213590	6/2004
TW	D112283	8/2006
TW	D119092	9/2007

**OTHER PUBLICATIONS**

Frequency-and Time-Domain Modeling of Tapered Loop Antennas in Ultra-Wideband Radio Systems, Shiou-Li Chen and Shau-Gang Mao, Graduate Institute of Computer and Communication Engineer, pp. 179-182, IEEE copyright notice 2006.

(Continued)

*Primary Examiner*—T. Chase Nelson  
*Assistant Examiner*—John Windmuller  
(74) *Attorney, Agent, or Firm*—Harness, Dickey & Pierce, P.L.C.

(57) **CLAIM**

The ornamental design for a tapered loop antenna element, as shown and described.

**DESCRIPTION**

FIG. 1 is a perspective view of the tapered loop antenna element, showing our new design;

FIG. 2 is a front elevation view thereof;

FIG. 3 is a back elevation thereof;

FIG. 4 is a bottom plan view thereof;

FIG. 5 is a top plan view thereof;

FIG. 6 is a right elevation view thereof;

FIG. 7 is a left elevation view thereof; and,

FIG. 8 is an exploded perspective view thereof in use.

In the drawings, the broken lines depict environmental subject matter only and form no part of the claimed design.

**1 Claim, 6 Drawing Sheets**

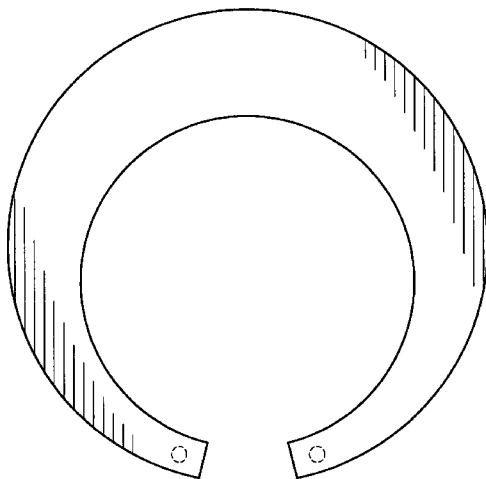

## U.S. PATENT DOCUMENTS

2004/0090379 A1 \* 5/2004 Fourdeux et al. .... 343/700 MS  
 2004/0090385 A1 \* 5/2004 Green ..... 343/702  
 2004/0113841 A1 \* 6/2004 Louzir et al. .... 343/700 MS  
 2005/0088342 A1 4/2005 Parsche  
 2005/0280582 A1 \* 12/2005 Powell et al. .... 343/700 MS  
 2006/0033665 A1 \* 2/2006 Yang ..... 343/700 MS  
 2006/0103577 A1 \* 5/2006 Lee ..... 343/700 MS  
 2006/0164304 A1 \* 7/2006 Huang et al. .... 343/700 MS  
 2007/0069955 A1 \* 3/2007 McCorkle ..... 343/700 MS  
 2008/0094291 A1 \* 4/2008 Bystrom et al. .... 343/702  
 2008/0211720 A1 \* 9/2008 Hansen ..... 343/700 MS  
 2009/0058732 A1 \* 3/2009 Nakano et al. .... 343/700 MS

## OTHER PUBLICATIONS

Planar Miniature Tapered-Slot-Fed Annular Slot Antennas for Ultrawide-Band Radios, Tzyh-Ghuang Ma, Student Member, and Shyh-Kang, Jeng, Senior Member, IEEE, IEEE Transactions on Antennas and Propagation, vol. 53, No. 3, Mar. 2005, pp. 1194-1202.  
 Self-Mutual Admittances of Two Identical Circular Loop Antennas in a Conducting Medium and in Air, K. Iizuka, Senior Member, IEEE,

R. W. P. King, Fellow, IEEE, and C. W. Harrison, Jr., Senior Member, IEEE, IEEE Transactions on Antennas and Propagation, vol. AP014, No. 4, Jul. 1966, pp. 440-450.

A Broadband Eccentric Annular Slot Antenna, Young Hoon Suh and Ikmo Park, Department of Electrical Engineering, Ajou University, pp. 94-97, IEEE copyright notice 2001.

A Printed Crescent Patch Antenna for Ultrawideband Applications, Ntsanderh C. Azenui an H.Y.D. Yang, IEEE Antennas and Wireless Propagation Letters, vol. 6, 2007, pp. 113-116.

Design of Compact Components for Ultra Wideband Communication Front Ends, Marek Bialkowski, Amin Abbosh, and Hing Kan, School of Information Technology and Electrical Engineering, The University of Queensland, four pages.

Antenna Engineering Handbook, 3rd Edition, Edited by Richard C. Johnson, McGraw Hill, 1993, pp. 5-13 to 5-16.

One-Element Loop Antenna with Finite Reflector, B. Rojarayanont and T. Sekiguchi, Electronics & Communications in Japan, vol. 59-B, No. 5, May 1976, p. 68.

IEEE Spectrum: Antennas for the New Airwaves, <http://www.spectrum.ieee.org/print/7328>, Published Feb. 2009, 9 pages, Authors Richard Schneider and John Ross.

\* cited by examiner

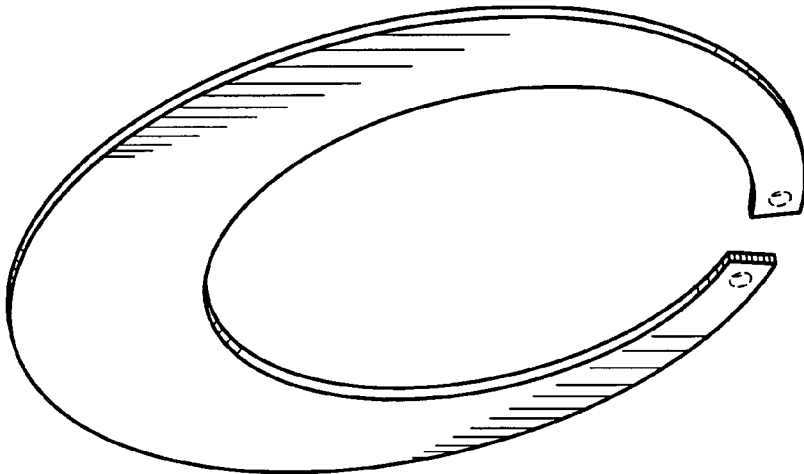

Fig. 1

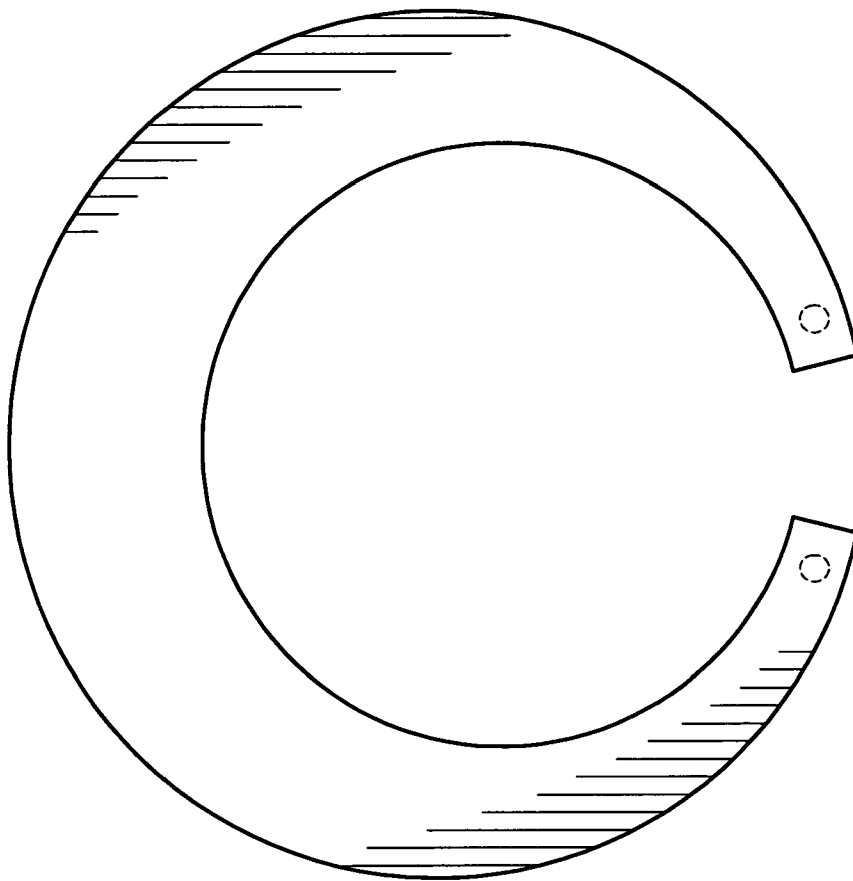

Fig. 2

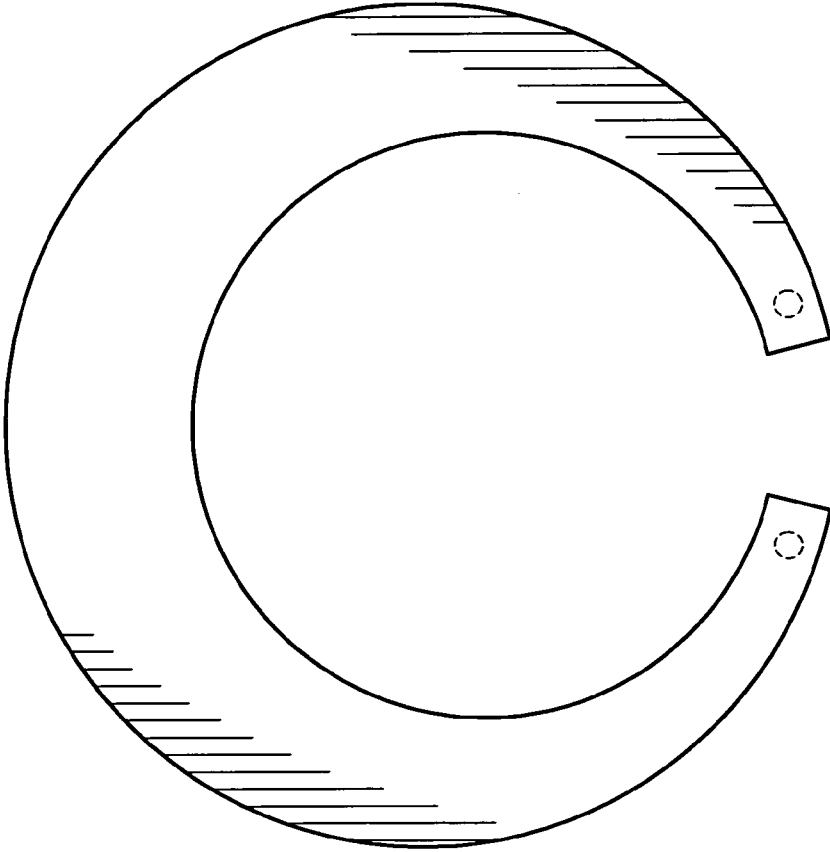

Fig. 3



Fig. 4



Fig. 5



Fig. 7



Fig. 6

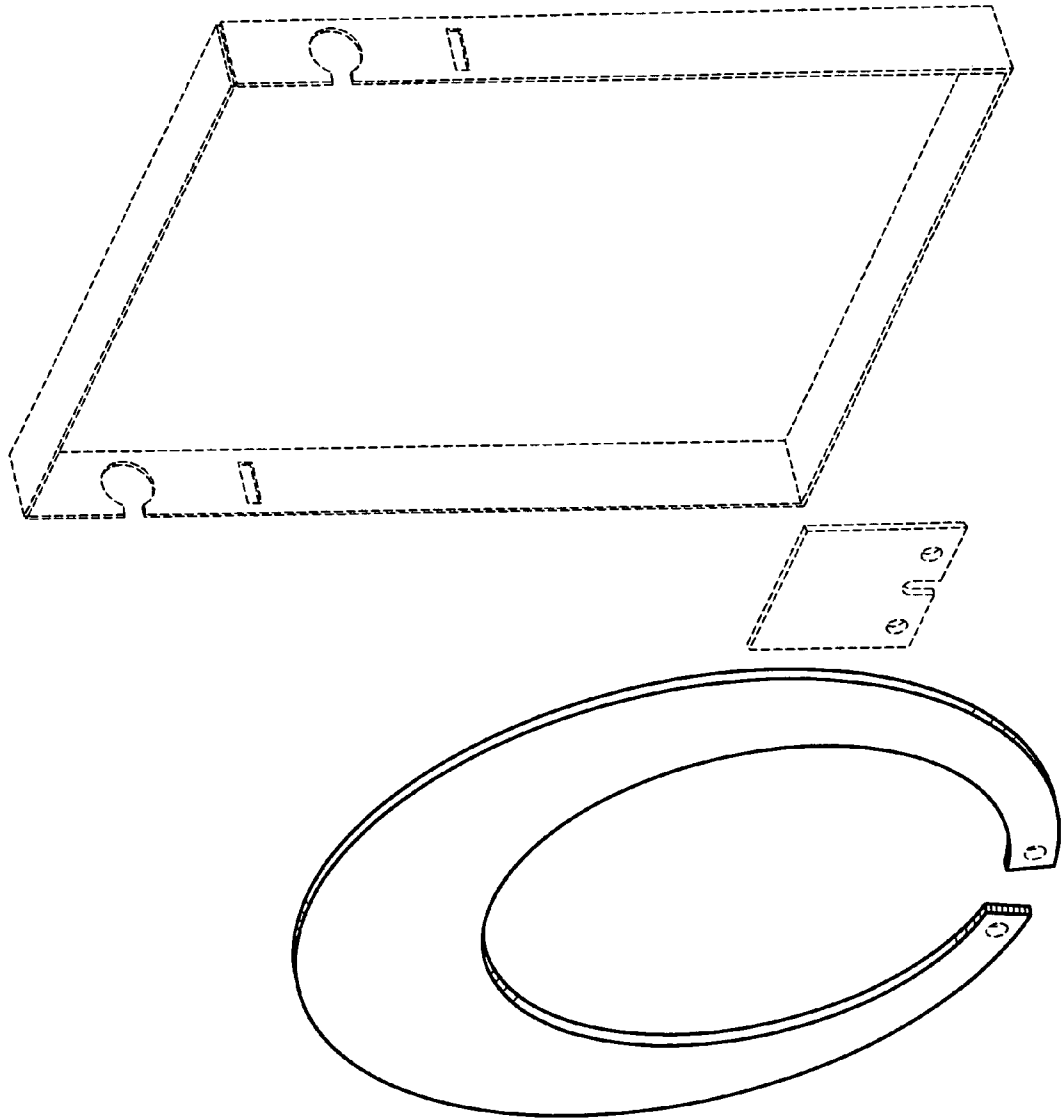

Fig. 8