



(12) **United States Design Patent**  
**Ross, III et al.**

(10) **Patent No.:** **US D951,658 S**  
(45) **Date of Patent:** **\*\* May 17, 2022**

- (54) **PICTURE FRAME ANTENNA**
- (71) Applicant: **Antennas Direct, Inc.**, Ellisville, MO (US)
- (72) Inventors: **John Edwin Ross, III**, Moab, UT (US); **Joanne Nosiglia**, Eureka, MO (US); **Christine Hand**, St. Louis, MO (US)
- (73) Assignee: **Antennas Direct, Inc.**, Ellisville, MO (US)
- (\*\*) Term: **15 Years**
- (21) Appl. No.: **29/781,095**
- (22) Filed: **Apr. 28, 2021**

**Related U.S. Application Data**

- (63) Continuation of application No. 29/635,829, filed on Feb. 2, 2018, now Pat. No. Des. 919,307, which is a continuation of application No. 29/587,310, filed on Dec. 12, 2016, now Pat. No. Des. 811,752, which is a continuation-in-part of application No. 15/277,362, filed on Sep. 27, 2016, now Pat. No. 10,128,575, which is a continuation-in-part of application No. 14/878,504, filed on Oct. 8, 2015, now Pat. No. 9,761,935.
- (51) **LOC (13) Cl.** ..... **06-07**
- (52) **U.S. Cl.**  
USPC ..... **D6/300; D14/230**
- (58) **Field of Classification Search**  
USPC ..... **D6/300-314; D14/448, 450, 239, 230**  
CPC . **A47G 1/00; A47G 1/06; A47G 1/005; A47G 1/0627; A47G 1/0638; A47G 1/14; A47G 1/141; A47G 1/142; A47G 1/10; A47G 1/0633**  
See application file for complete search history.

(56) **References Cited**

U.S. PATENT DOCUMENTS

2,060,098	A	11/1936	Norman
2,220,008	A	10/1940	Woodward et al.
2,437,251	A	3/1948	Frische et al.
2,480,155	A	8/1949	Masters
2,551,664	A	5/1951	Galper
2,589,578	A	3/1952	Sabins
D168,325	S	12/1952	Abrams
D170,203	S	8/1953	Leonard
D171,560	S	2/1954	Ritter
D177,200	S	3/1956	Valiulis
D179,111	S	11/1956	Ballan
2,821,710	A	1/1958	Hale
3,015,101	A	12/1961	Turner et al.
3,123,826	A	3/1964	Durham
3,161,975	A	12/1964	McMillan
3,239,838	A	3/1966	Kelleher
3,261,019	A	7/1966	Lundy
D205,771	S	9/1966	Spiselman
3,273,158	A	9/1966	Fouts et al.
D209,402	S	11/1967	Burlingame
D211,025	S	5/1968	Callaghan
3,434,145	A	3/1969	Wells
D213,882	S	4/1969	Sonnenblick
3,560,983	A	2/1971	Willie et al.
3,587,105	A	6/1971	Neilson
3,721,990	A	3/1973	Gibson et al.
3,828,867	A	8/1974	Elwood
3,971,031	A	7/1976	Burke
D244,771	S	6/1977	Bott
4,183,027	A	1/1980	Ehrenspeck
4,184,163	A	1/1980	Woodward
D269,838	S	7/1983	Altonaga
4,418,427	A	11/1983	Muterspaugh
4,462,010	A	7/1984	Strammello
D282,355	S	1/1986	Hartzell
D310,671	S	9/1990	Weiss
D312,923	S	12/1990	Bleazard
4,987,424	A	1/1991	Tamura et al.
D318,673	S	7/1991	Terk
D324,780	S	3/1992	Sebesta
D327,690	S	7/1992	Ogawa et al.
D332,262	S	1/1993	Borchardt
5,280,645	A	1/1994	Nguyen et al.
D344,731	S	3/1994	Witzky
5,313,218	A	5/1994	Busking
D358,037	S	5/1995	Monroe
D366,764	S	2/1996	Hunt
D396,350	S	7/1998	Panzenhagen
D405,473	S	2/1999	Tikhonski et al.

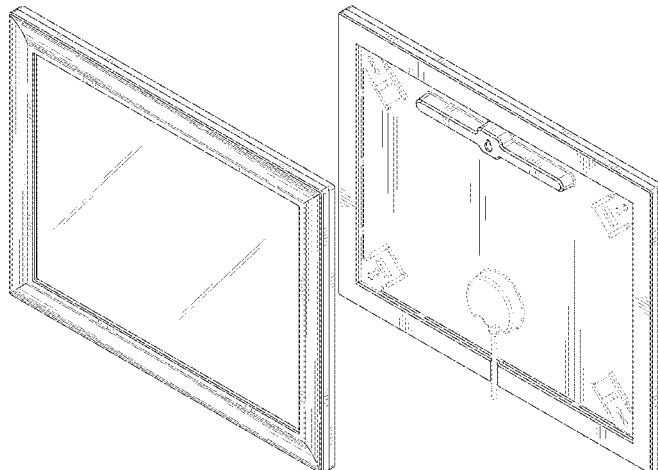

5,943,025 A	8/1999	Benham et al.	2004/0217912 A1	11/2004	Mohammadian	
D414,495 S	9/1999	Heiligenstein et al.	2005/0088342 A1	4/2005	Parsche	
D421,610 S	3/2000	Ghalebi	2005/0162332 A1	7/2005	Schantz	
6,054,963 A	4/2000	Muterspaugh	2005/0259023 A1	11/2005	Wang	
6,239,764 B1	5/2001	Timofeev et al.	2005/0280582 A1	12/2005	Powell et al.	
D449,593 S	10/2001	Schultz	2006/0033665 A1	2/2006	Yang	
D452,995 S	1/2002	Barry	2006/0055618 A1	3/2006	Poilasne et al.	
D474,037 S *	5/2003	Shih ..... D6/308	2006/0077115 A1	4/2006	Oh et al.	
6,590,541 B1	7/2003	Schultze	2006/0103577 A1	5/2006	Lee	
6,593,886 B2	7/2003	Schantz	2006/0164304 A1	7/2006	Huang et al.	
D480,221 S	10/2003	Luciano	2007/0069955 A1	3/2007	McCorkle	
D480,714 S	10/2003	Wang	2007/0200769 A1	8/2007	Nakano et al.	
D481,544 S	11/2003	Di Leggerini	2008/0094291 A1	4/2008	Bystrom et al.	
6,680,708 B2	1/2004	Yamaki	2008/0211720 A1	9/2008	Hansen	
D501,468 S	2/2005	Wang	2008/0258980 A1	10/2008	Chen et al.	
6,885,352 B2	4/2005	Lee et al.	2008/0291345 A1*	11/2008	Schneider ..... H04N 5/64	
D504,687 S	5/2005	Lee et al.				348/836
D505,018 S *	5/2005	Stravitz ..... D6/310	2008/0297438 A1*	12/2008	Lin ..... A47G 1/142	
D507,118 S *	7/2005	Stravitz ..... D6/300				345/30
6,917,793 B2	7/2005	Wang	2009/0058732 A1	3/2009	Nakano et al.	
D509,072 S	9/2005	Babich	2009/0073067 A1	3/2009	Soler Castany et al.	
D510,101 S	9/2005	Bushey	2009/0146899 A1	6/2009	Schneider et al.	
D519,117 S	4/2006	Lewis	2009/0146900 A1	6/2009	Schneider et al.	
D524,555 S	7/2006	Mohundro	2009/0147155 A1*	6/2009	Hsu ..... G06F 1/1601	
D527,193 S	8/2006	Park				348/836
7,091,925 B1	8/2006	Wang	2009/0289853 A1	11/2009	Tinaphong et al.	
7,126,556 B1	10/2006	Wang	2009/0316056 A1*	12/2009	Rosencwaig ..... G06F 1/1656	
D532,823 S	11/2006	Pena Angarita				455/344
7,209,089 B2	4/2007	Schantz	2010/0085269 A1	4/2010	Sadowski et al.	
D542,543 S	5/2007	Bruce	2012/0013513 A1	1/2012	Yukimasa	
D544,471 S	6/2007	Wang	2012/0169553 A1	7/2012	Nomura et al.	
7,239,290 B2	7/2007	Poilasne et al.	2012/0249396 A1	10/2012	Parsche	
7,245,266 B1	7/2007	Szente et al.	2013/0162487 A1	6/2013	Schneider	
D548,981 S	8/2007	Ernetoft	2014/0292597 A1	10/2014	Schneider et al.	
D558,189 S	12/2007	Inoue	2017/0062939 A1	3/2017	Ross, III et al.	
D575,531 S	8/2008	Paterson				
D581,931 S	12/2008	Pine				
D585,883 S	2/2009	Kaneko				
D598,433 S	8/2009	Schneider et al.				
D598,434 S	8/2009	Schneider et al.				
7,609,222 B2	10/2009	Schneider et al.				
D604,276 S	11/2009	Schneider et al.				
D611,460 S	3/2010	Chao				
7,693,570 B2	4/2010	Green et al.				
D624,531 S	9/2010	Fleck et al.				
7,839,347 B2	11/2010	Schneider et al.				
7,839,351 B2	11/2010	Schadler et al.				
7,898,496 B2	3/2011	Olsen et al.				
D638,631 S	5/2011	Parisi et al.				
7,936,311 B2	5/2011	Rowser et al.				
7,990,335 B2	8/2011	Schneider et al.				
D654,274 S	2/2012	Krawczyk				
D666,178 S	8/2012	Schneider et al.				
D666,619 S	9/2012	May				
8,368,607 B2	2/2013	Schneider et al.				
D677,474 S	3/2013	Harris et al.				
D719,744 S	12/2014	Plumbo et al.				
D719,746 S	12/2014	Dean, Jr.				
D735,480 S	8/2015	Fallon				
D782,211 S	3/2017	Randhawa				
9,761,935 B2	9/2017	Ross, III et al.				
D811,752 S *	3/2018	Ross, III ..... D14/230				
10,128,575 B2	11/2018	Ross, III et al.				
D854,343 S *	7/2019	Altemimei ..... D6/300				
D878,775 S *	3/2020	Wang ..... D14/371				
D884,366 S *	5/2020	Gao ..... D14/371				
D884,367 S *	5/2020	Gao ..... D14/371				
10,693,239 B2 *	6/2020	Ross, III ..... H01Q 7/00				
D893,201 S *	8/2020	Jiang ..... D14/374				
D900,488 S *	11/2020	Chu ..... D14/341				
D900,489 S *	11/2020	Chu ..... D14/341				
D901,191 S *	11/2020	Chu ..... D14/341				
D901,192 S *	11/2020	Wang ..... D14/371				
D919,307 S *	5/2021	Ross, III ..... D14/230				
2002/0158798 A1	10/2002	Chiang et al.				
2003/0071757 A1	4/2003	Yamaki				
2004/0090379 A1	5/2004	Fourdeux et al.				
2004/0090385 A1	5/2004	Green				
2004/0113841 A1	6/2004	Louzir et al.				

FOREIGN PATENT DOCUMENTS

CN 1474478 A 2/2004  
 CN 203589214 U 5/2014

OTHER PUBLICATIONS

Non-final Office Action for U.S. Appl. No. 16/184,594, filed Nov. 8, 2018 which claims priority to the same parent application as the instant application; dated Jan. 14, 2020; 12 pages.  
 Notice of Allowance dated Jan. 25, 2018 for design U.S. Appl. No. 29/587,310, filed Dec. 12, 2016 which is the parent application to the instant application, 8 pages.  
 Chinese office action (and its English translation) for Chinese application No. 201610797981.6 which claims priority to the same parent application as the instant application, dated Nov. 21, 2018, 18 pages.

\* cited by examiner

Primary Examiner — Deanna L Pratt  
 (74) Attorney, Agent, or Firm — Harness, Dickey & Pierce, P.L.C.; Anthony G. Fussner

(57) CLAIM

The ornamental design for a picture frame antenna, as described herein and shown in FIGS. 1 through 9, FIGS. 10 through 14, or FIGS. 15 through 20.

DESCRIPTION

FIG. 1 is a perspective view of a first embodiment of a picture frame antenna, showing our new design;  
 FIG. 2 is a back perspective view of the picture frame antenna shown in FIG. 1;

FIG. 3 is a front elevation view of the picture frame antenna shown in FIG. 1;

FIG. 4 is a back elevation of the picture frame antenna shown in FIG. 1;

FIG. 5 is a right elevation view of the picture frame antenna shown in FIG. 1;

FIG. 6 is a left elevation view of the picture frame antenna shown in FIG. 1;

FIG. 7 is a top plan view of the picture frame antenna shown in FIG. 1;

FIG. 8 is a bottom plan view of the picture frame antenna shown in FIG. 1;

FIG. 9 is an exploded perspective view of the picture frame antenna shown in FIG. 1 showing an exemplary antenna element in broken lines that may be coupled to an inner surface of the back plate and disposed within an interior defined by the picture frame antenna;

FIG. 10 is a perspective view of a second embodiment of a picture frame antenna, showing our new design;

FIG. 11 is an elevation view of the picture frame antenna shown in FIG. 10;

FIG. 12 is a left elevation view of the picture frame antenna shown in FIG. 10;

FIG. 13 is a right elevation view of the picture frame antenna shown in FIG. 10;

FIG. 14 is a bottom plan view of the picture frame antenna shown in FIG. 10;

FIG. 15 is a perspective view of a third embodiment of a picture frame antenna, showing our new design;

FIG. 16 is an elevation view of the picture frame antenna shown in FIG. 15;

FIG. 17 is a left elevation view of the picture frame antenna shown in FIG. 15;

FIG. 18 is a right elevation view of the picture frame antenna shown in FIG. 15;

FIG. 19 is a top plan view of the picture frame antenna shown in FIG. 15; and,

FIG. 20 is a bottom plan view of the picture frame antenna shown in FIG. 15.

In the drawings, the details shown in broken lines depict environmental subject matter only and form no part of the claimed design.

**1 Claim, 12 Drawing Sheets**

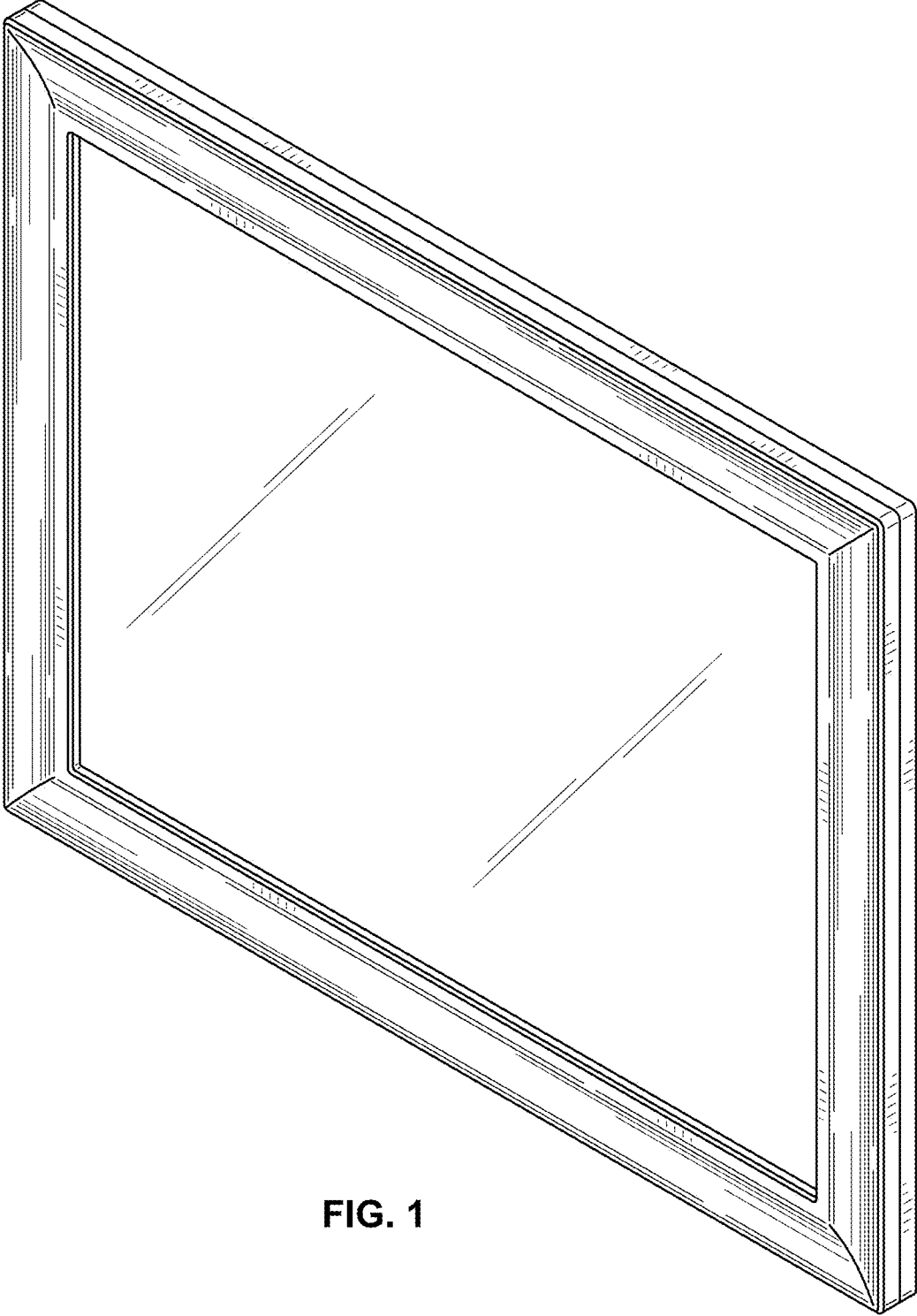

FIG. 1

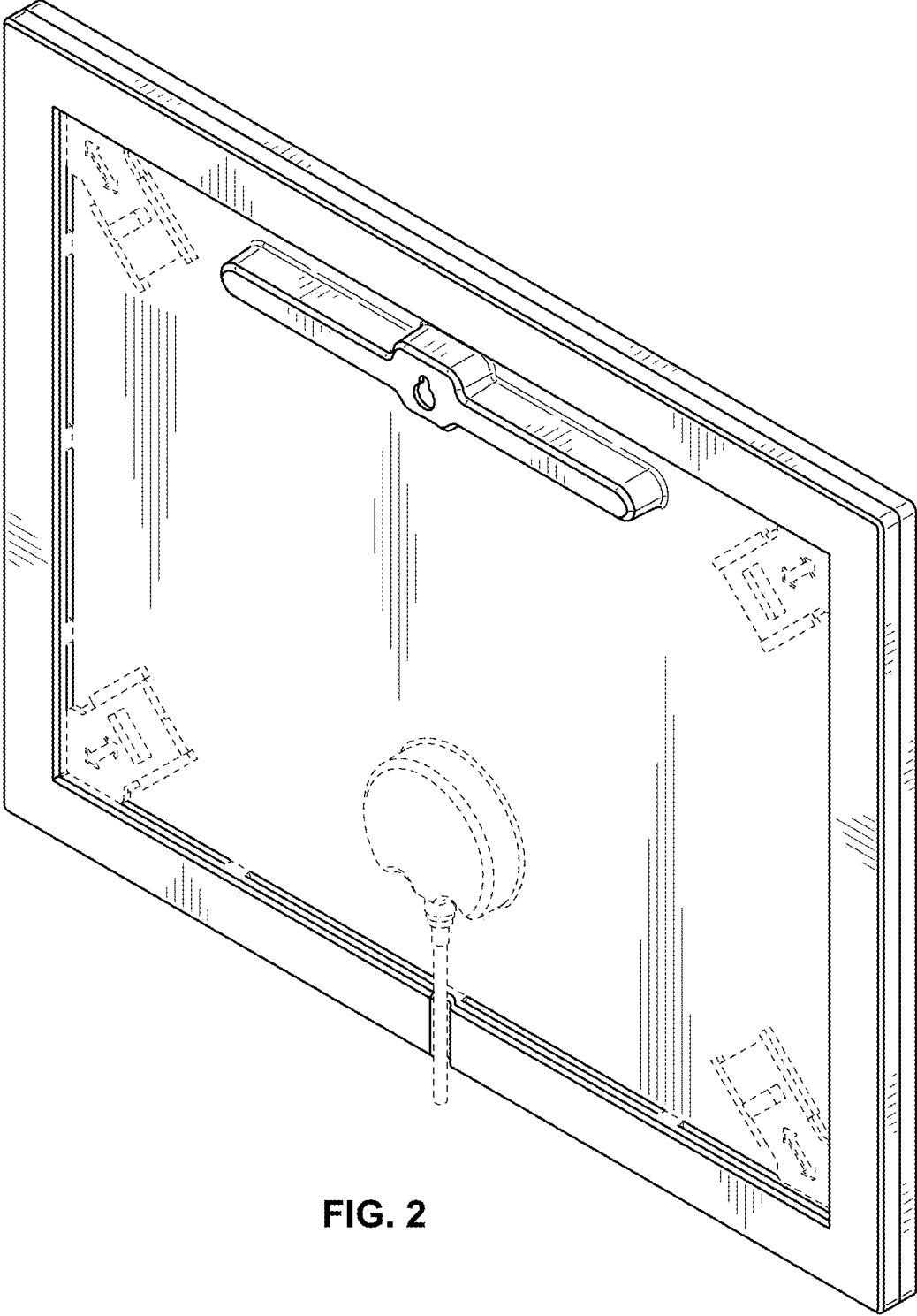

FIG. 2

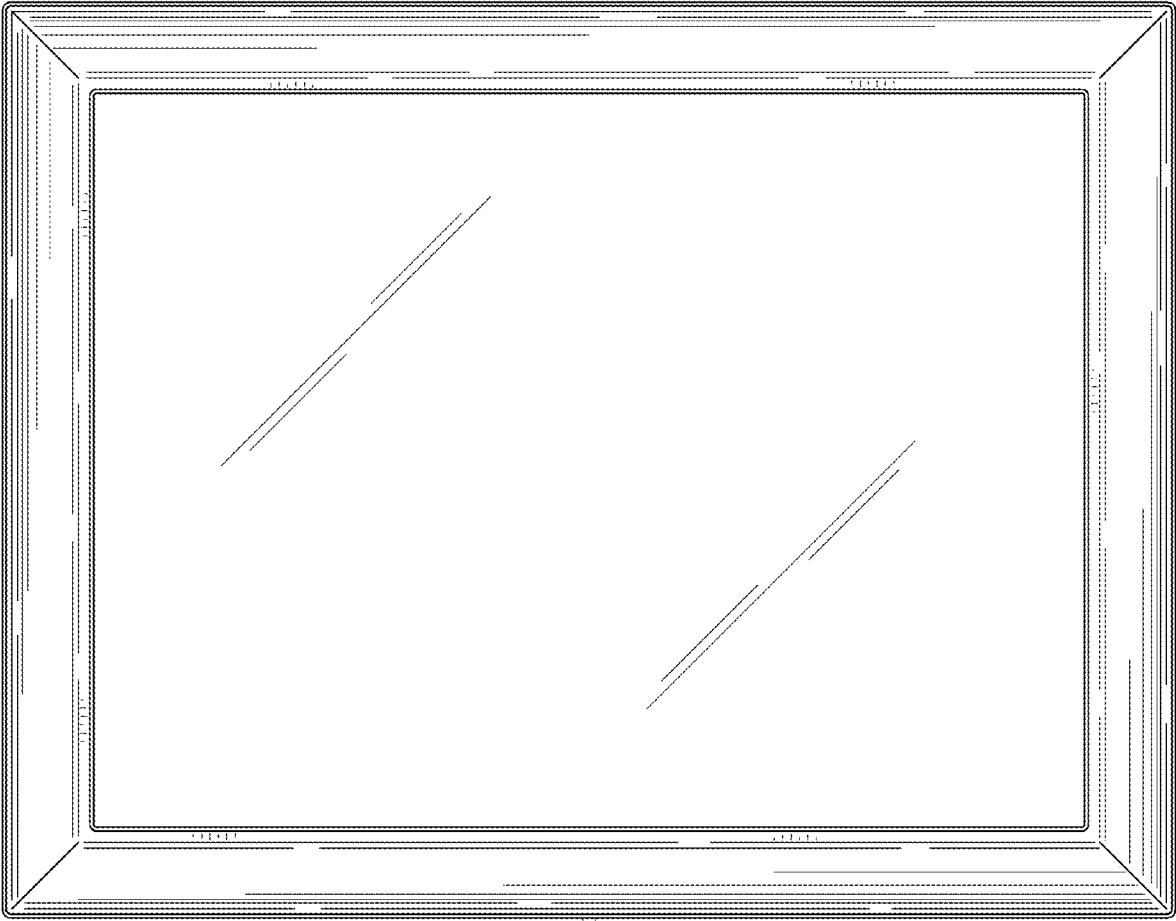

FIG. 3

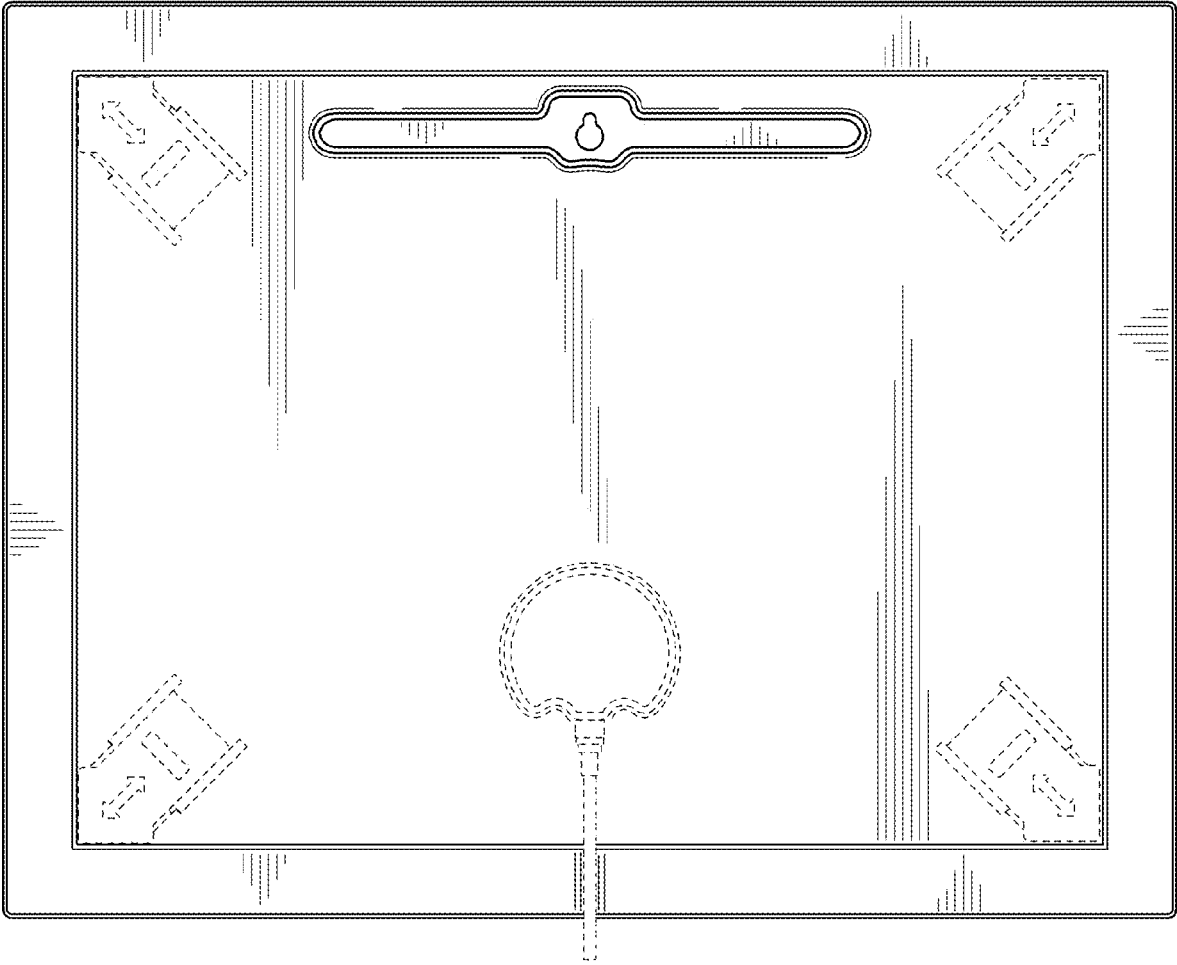

FIG. 4

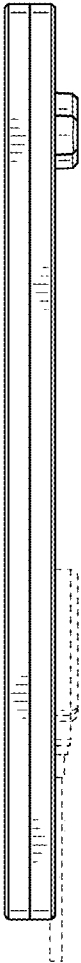

FIG. 5

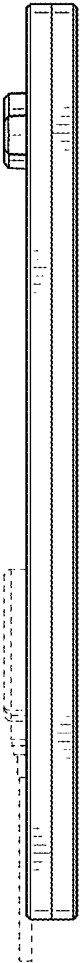

FIG. 6

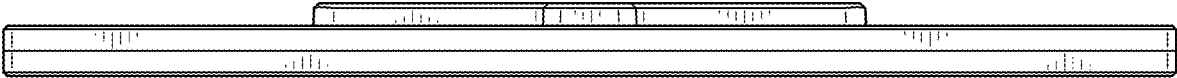

FIG. 7



FIG. 8



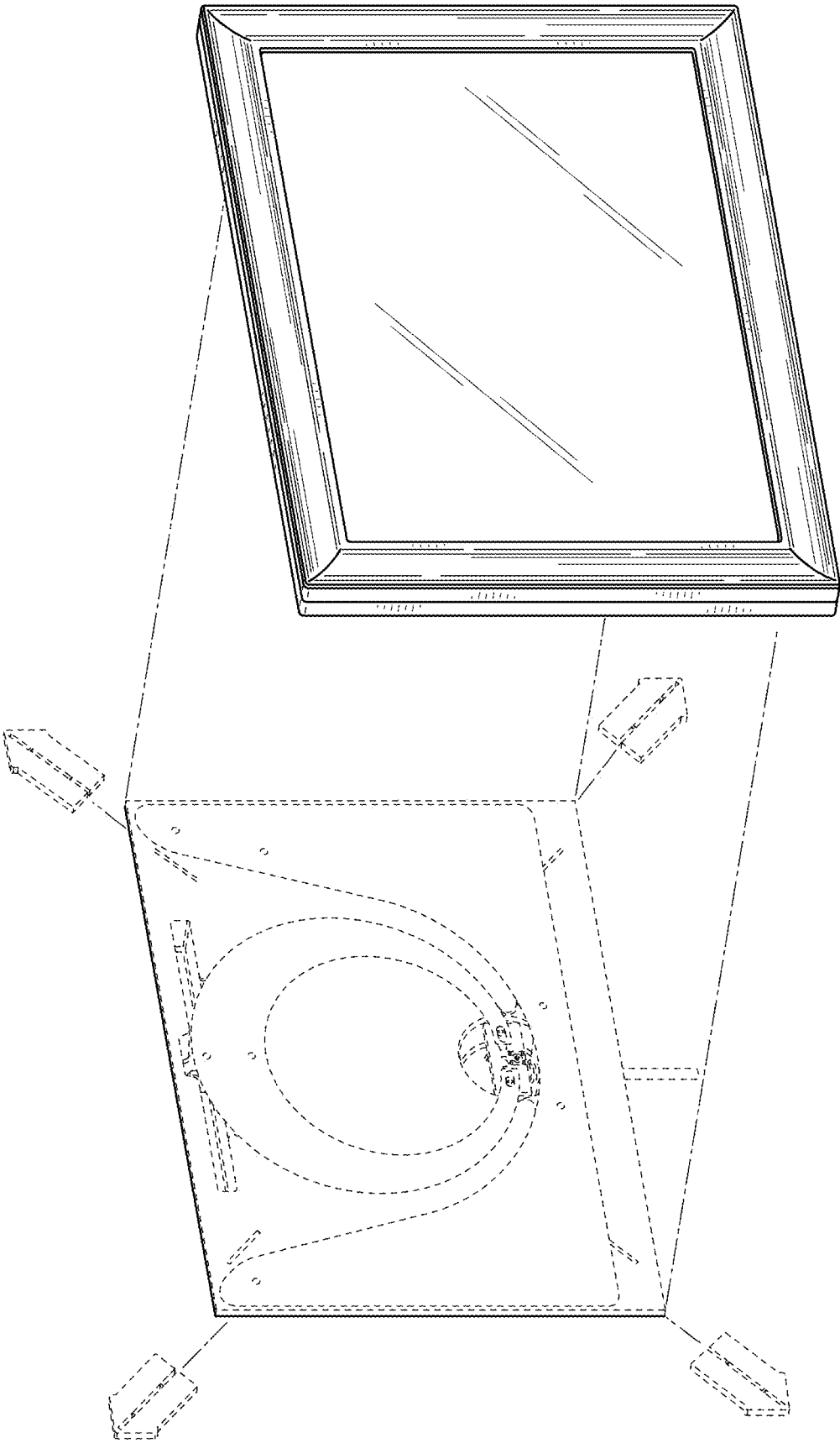

FIG. 9

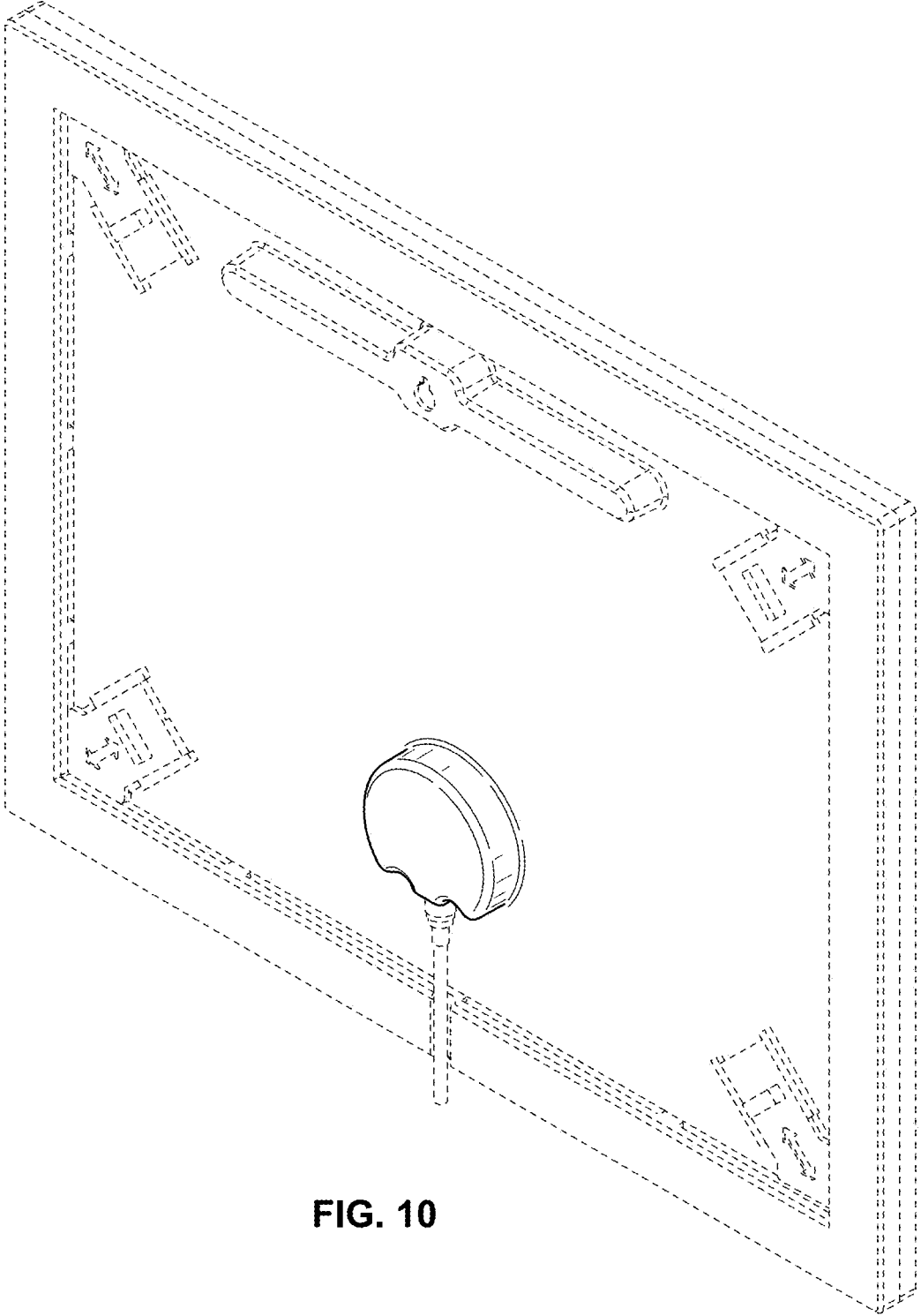

FIG. 10

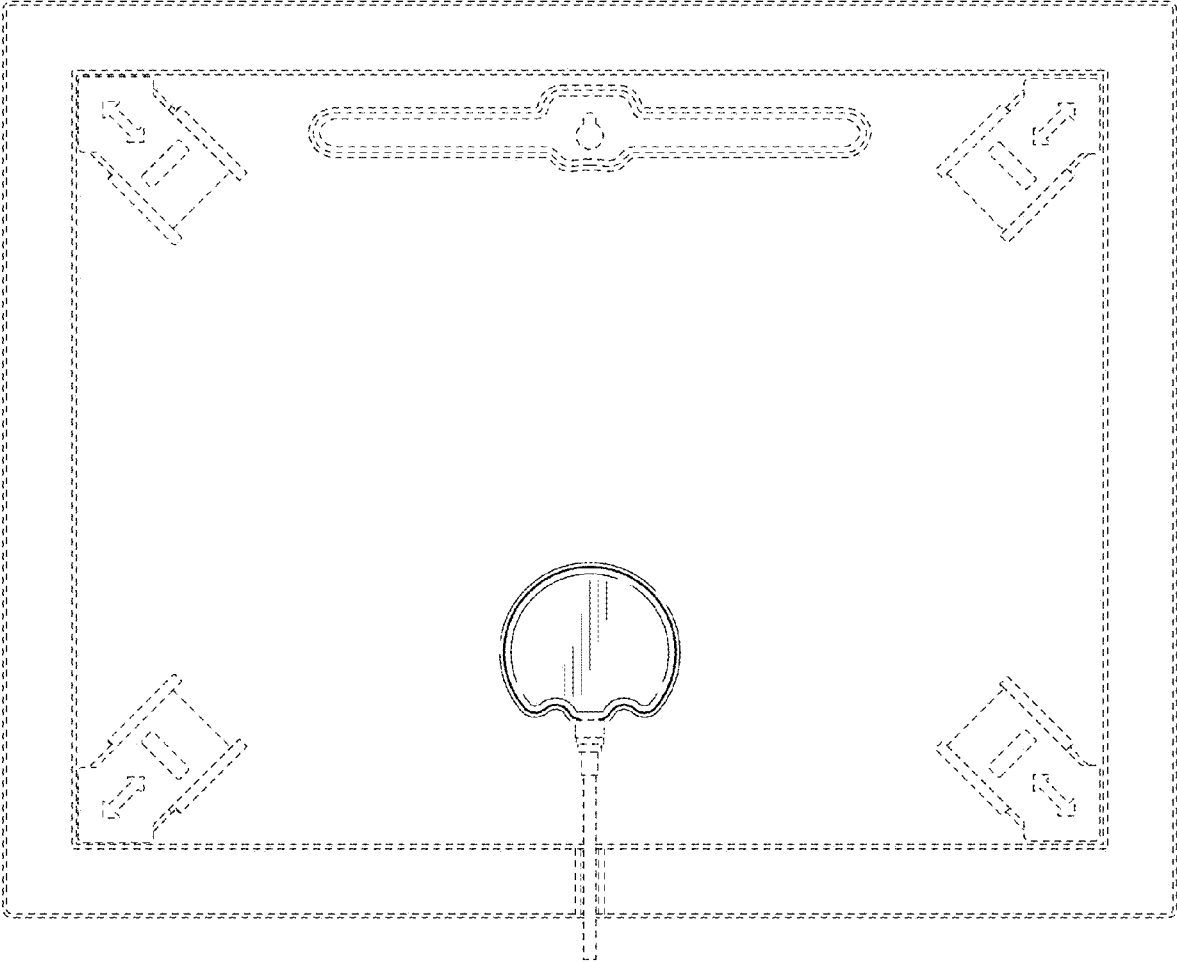

FIG. 11

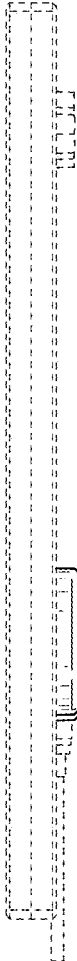

FIG. 12

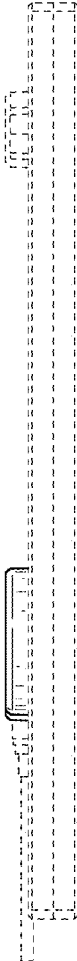

FIG. 13



FIG. 14

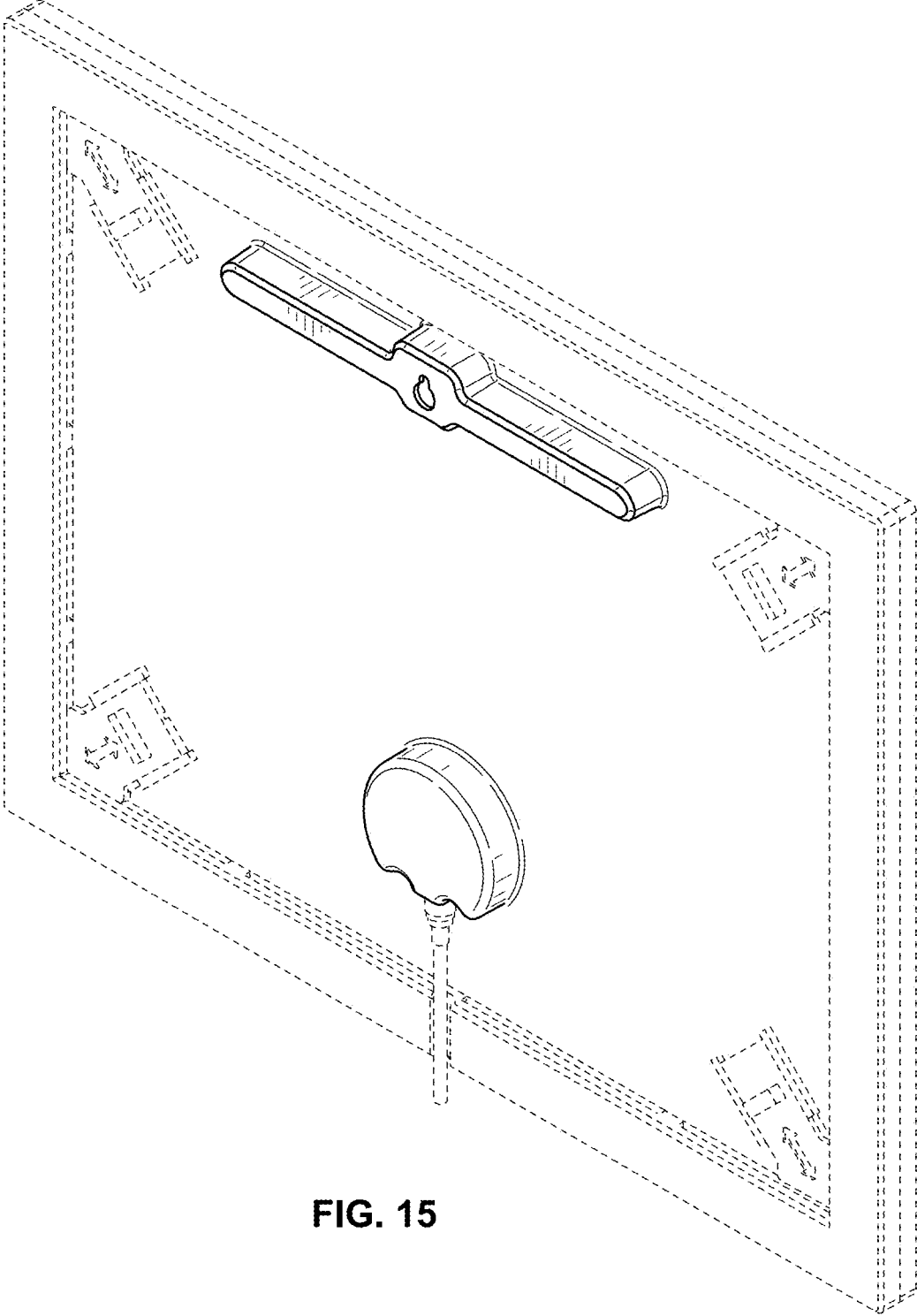

FIG. 15

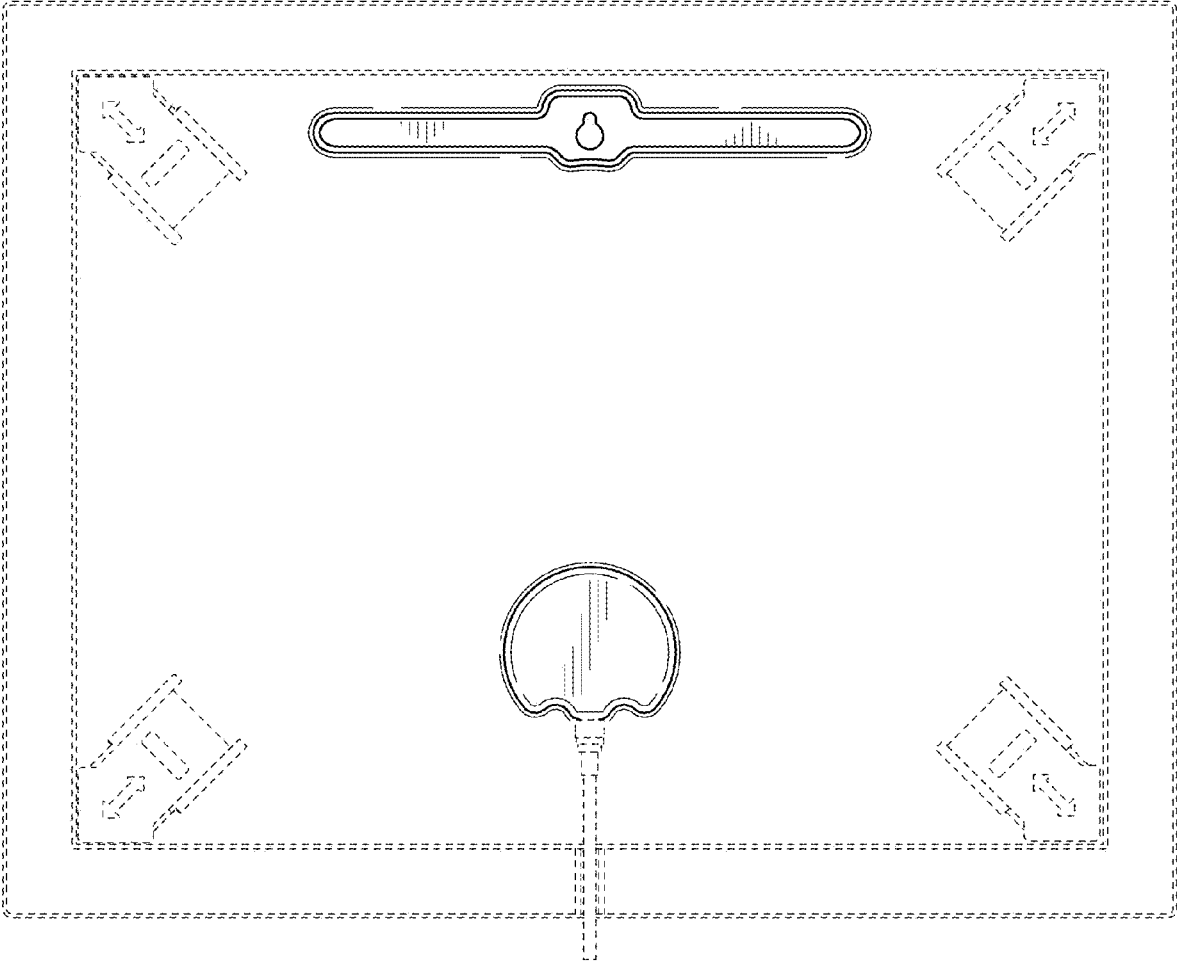

FIG. 16

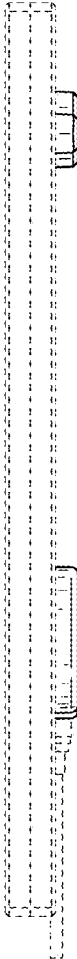

FIG. 17

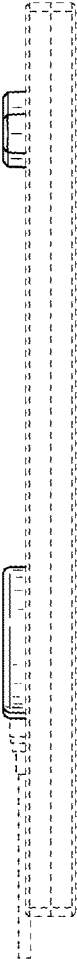

FIG. 18

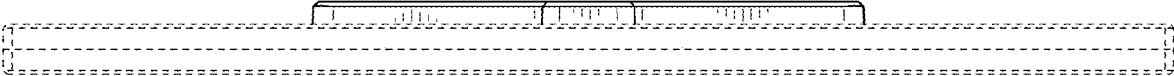

FIG. 19



FIG. 20